



**DELTA**

Xfinity Ultra Enpro 13

33VB024C24

33VB036C24

33VB048C24

33VB060C24

# INSTRUCTION MANUAL

**WARNING!**

Read and follow all safety precautions in Instruction Manual - improper use can cause serious injury.

## Contents

Safety Considerations .....	1
1. Unit Parts Arrangement .....	2
2. Physical Dimension .....	2
2.1 Outdoor Unit .....	2
2.2 Installation Clearance Data .....	4
2.3 Units Installation .....	4
2.4 Installation Recommendations .....	5
3. Brazing Connections .....	6
3.1 Preparation the Line .....	6
3.2 Cap and Core Removal .....	7
3.3 Attach Gauge .....	7
3.4 Braze Line Set .....	7
3.5 Preparation for Next Step .....	8
4. Check Piston .....	8
5. Operating Gauge Set and Service Valves .....	9
5.1 Torque Requirements .....	9
5.2 Using Manifold Gauge Set .....	9
5.3 Operating Service Valves .....	9
5.4 Operating Angle Type Service Valve .....	9
5.5 To Access Service Port .....	10
5.6 Reinstall Stem Cap .....	10

- 5.7 Install Liquid Line Filter Drier Indoor ..... 10
- 6. Recovering Refrigerant from Existing System..... 11
  - 6.1 Disconnect Power ..... 11
  - 6.2 Connect Manifold Gauge Set ..... 11
  - 6.3 Recovering Refrigerant ..... 11
  - 6.4 Leak Test Line Set and Indoor Coil..... 12
  - 6.5 Evacuating Line Set and Indoor Coil ..... 13
- 7. Electrical ..... 14
  - 7.1 Size Circuit And Install Disconnect Switch ..... 15
  - 7.2 Install Thermostat ..... 15
  - 7.3 Unit Low Voltage Connections ..... 15
  - 7.4 Unit High Voltage Connections..... 16
- 8. System Refrigerant..... 20
  - 8.1 Gauge Set (Cooling Only) ..... 20
  - 8.2 Gauge Set (Heat Pump) ..... 21
  - 8.3 Weigh In ..... 22
- 9. Unit Control..... 26
  - 9.1 Mainboard Description ..... 26
  - 9.2 Terminal Description ..... 27
  - 9.3 Control Flowchart ..... 28
  - 9.4 Error Analysis ..... 29
  - 9.5 Setting on Defrost Control PCB (for Heat Pump unit only) ..... 32
  - 9.6 Manually Defrost Cycle ..... 32

## Safety Considerations

Improper installation, adjustment, alteration, service, maintenance, or use can cause explosion, fire, electrical shock, or other conditions which may cause death, personal injury, or property damage. Instructions for installation and use of this product are provided by the manufacturer. Installation must be performed in accordance with the requirements of NEC and CEC by qualified installer or agency only. The qualified installer or agency must use factory--authorized kits or accessories when modifying this product. Refer to the individual instructions packaged with the kits or accessories when installing. Follow all safety codes. Wear safety glasses, protective clothing, and work gloves. Use quenching cloth for brazing operations. Have fire extinguisher available. Read these instructions thoroughly and follow all warnings or cautions included in literature and attached to the unit. Consult local building codes and National Electrical Code (NEC) for special requirements. Recognize safety information. This is the safety--alert symbol .When you see this symbol on the unit and in instructions or manuals, be alert to the potential for personal injury. Understand these signal words; DANGER, WARNING, and CAUTION. These words are used with the safety--alert symbol. DANGER identifies the most serious hazards which will result in severe personal injury or death. WARNING signifies hazards which could result in personal injury or death. CAUTION is used to identify unsafe practices which may result in minor personal injury or product and property damage. NOTE is used to highlight suggestions which will result in enhanced installation, reliability, or operation.



### **WARNING**

#### **ELECTRICAL SHOCK HAZARD**

Failure to follow this warning could result in personal injury or death.

Before installing, modifying, or servicing system, main electrical disconnect switch must be in the OFF position. There may be more than 1 disconnect switch. Lock out and tag switch with a suitable warning label.



**This product must not be disposed together with the domestic waste.  
This product has to be disposed at an authorized place for recycling of  
electrical and electronic appliances.**

# 1. Unit Parts Arrangement

## Cooling Only Condensing Unit

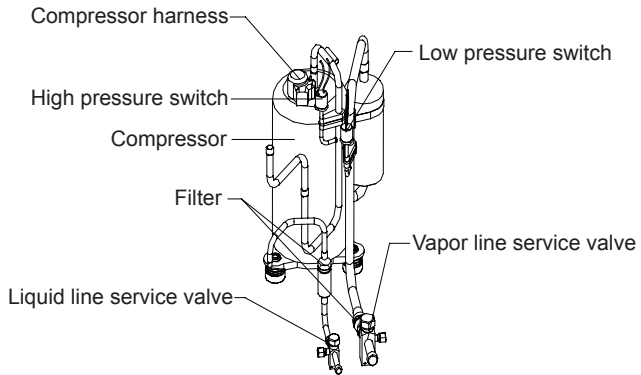

Fig.1

## Heat Pump Condensing Unit

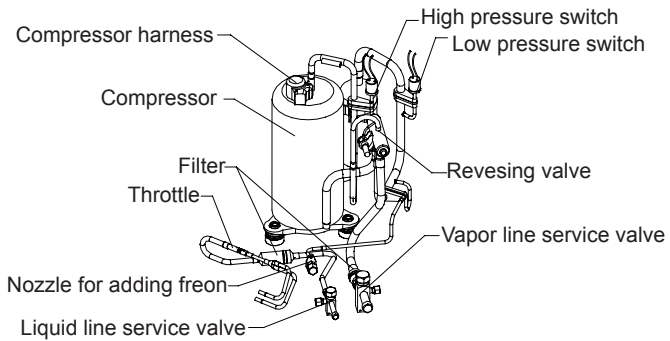

Fig.2

# 2. Physical Dimension

## 2.1 Outdoor Unit

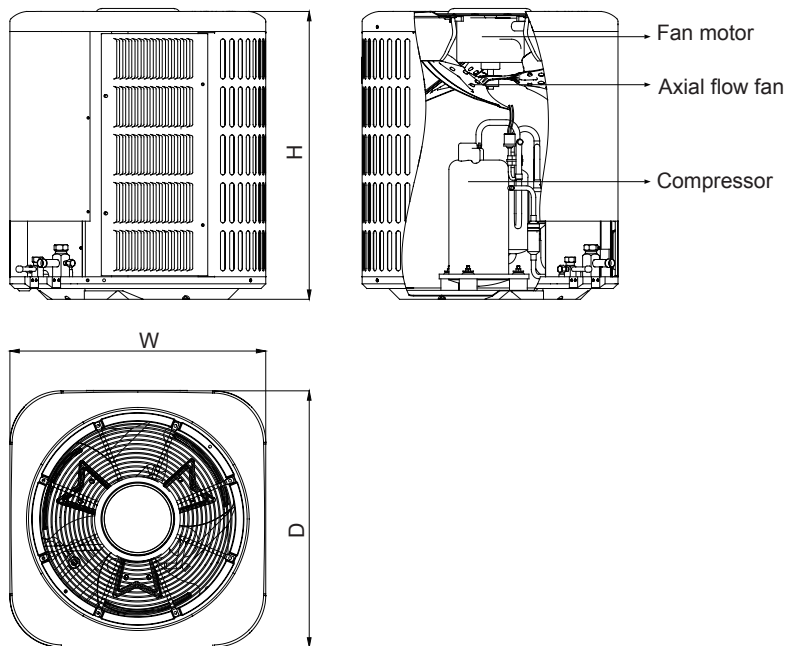

Fig.3—Outdoor Unit

Table 1—Dimension of Outdoor Unit

Unit: Inch (mm)

MODEL	DIMENSION		
	H	D	W
33VB018C24	24"(610)	21-1/2"(546)	21-1/2"(546)
33VB024C24	24-1/2"(620)	24"(610)	24"(610)
33VB030C24	29"(735)	24"(610)	24"(610)
33VB036C24	29"(735)	28"(710)	28"(710)
33VB042C24	29"(735)	28"(710)	28"(710)
33VB048C24	29"(735)	28"(710)	28"(710)
33VB060C24	33-1/2"(850)	29-1/2"(750)	29-1/2"(750)
33VB018H24	24-1/2"(620)	24"(610)	24"(610)
33VB024H24	24-1/2"(620)	24"(610)	24"(610)
33VB030H24	29"(735)	28"(710)	28"(710)
33VB036H24	29"(735)	28"(710)	28"(710)
33VB042H24	29"(735)	28"(710)	28"(710)
33VB048H24	33-1/2"(850)	28"(710)	28"(710)
33VB060H24	33-1/2"(850)	29-1/2"(750)	29-1/2"(750)

## 2.2 Installation Clearance Data

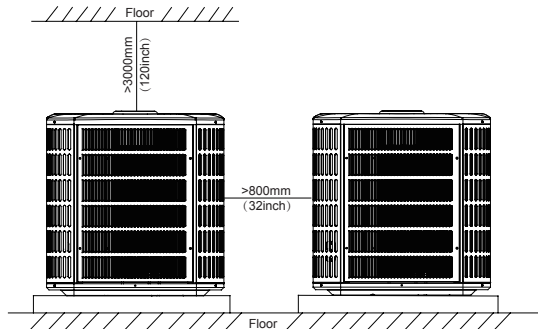
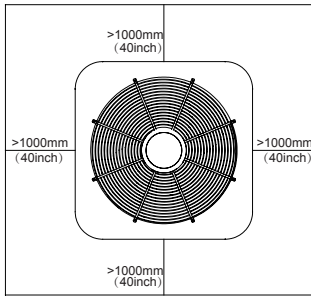

Fig.4

## 2.3 Units Installation

### 3.3.1 Installation Positions of Condensing Units

- Outdoor Unit must be fixed on stable and solid surface of floor.
- Don't install Outdoor Unit under window or between buildings, and prevent the operation noise from room.
- There should be no obstructions at both air inlet and outlet of indoor and outdoor units for maintaining well air ventilation.
- When installing indoor unit, make sure that the hanging parts at top are strong enough to stand the weight of unit.

### 3.3.2 Matters Need Attention

- Before installation, make sure that the power supply comply with nameplate and check the security of the power supply.
- Do not use or place combustible and explosive gas or liquid near the air conditioner.
- Do not attempt to install Air Conditioner by yourself to guarantee the air Conditioner can be permanent use.
- In the event of malfunction(burning smell, etc.),stop operation immediately and turn off the power switch.
- Do not insert fingers or objects into the outlet port or inlet grillers.
- Do not check or repair the air Conditioner when it is running.
- Do not sprinkle water on the air Conditioner or operate it with wet hands.
- Do not climb or place objects on the air conditioner.

## 2.4 Installation Recommendations

**NOTE:** In some cases noise in the living area has been traced to gas pulsations from improper installation of equipment.

- 1). Locate unit away from windows, patios, decks, etc. where unit operation sound may disturb customer.
- 2). Ensure that vapor and liquid tube diameters are appropriate for unit capacity.
- 3). Run refrigerant tubes as directly as possible by avoiding unnecessary turns and bends.
- 4). Leave some slack between structure and unit to absorb vibration.
- 5). When passing refrigerant tubes through the wall, seal opening with RTV or other pliable silicon--based caulk.(See Fig. 5.)
- 6). Avoid direct tubing contact with water pipes, duct work, floor joists, wall studs, floors, and walls.
- 7). Do not suspend refrigerant tubing from joists and studs with a rigid wire or strap which comes in direct contact with tubing. (See Fig. 5.)
- 8). Ensure that tubing insulation is pliable and completely surrounds vapor tube.
- 9). When necessary, use hanger straps which are 1 in. wide and conform to shape of tubing insulation. (See Fig. 5.)
- 10). Isolate hanger straps from insulation by using metal sleeves bent to conform to shape of insulation.

When outdoor unit is connected to factory--approved indoor unit, outdoor unit contains system refrigerant charge good for 25 ft.

For proper unit operation, check refrigerant charge using charging information located on control box cover and/or in the Check Charge section of this instruction.

NOTE: Avoid contact between tubing and structure

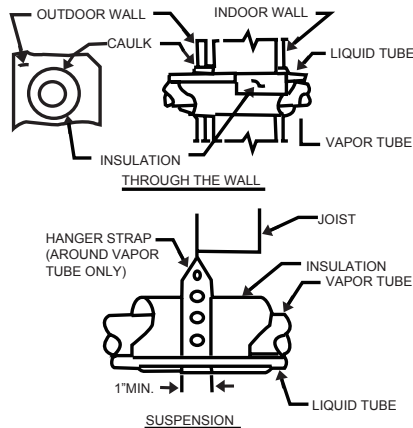

Fig.5 – Connecting Tubing Installation



### 3. Brazing Connections

#### 3.1 Preparation the Line

Refer to Table 2 for field tubing diameters. The pipe must remain round. Do not crimp end of the line.

Table 2. Refrigerant Line Set Inches (mm)

Model	Valve Field Connections	
	Liquid Line	Vapor Line
33VB018C24	3/8 in. (9.5 mm)	5/8 in. (16 mm)
33VB018H24		
33VB024C24		
33VB024H24		
33VB030C24		
33VB030H24		
33VB036C24		3/4 in. (19 mm)
33VB036H24		
33VB042C24		
33VB042H24		7/8 in. (22 mm)
33VB048C24		
33VB048H24		
33VB060C24		
33VB060H24	1/2 in. (12 mm)	1-1/8 in. (28 mm)

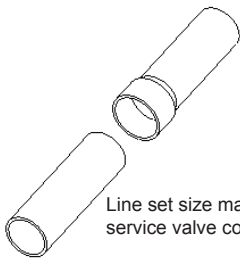

Line set size matches service valve connection

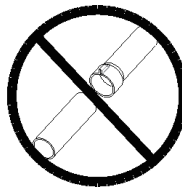

Do not crimp service valve connector when pipe is smaller than connection

Fig.6

### 3.2 Cap and Core Removal

Remove service cap and core from both the vapor and liquid line service ports.

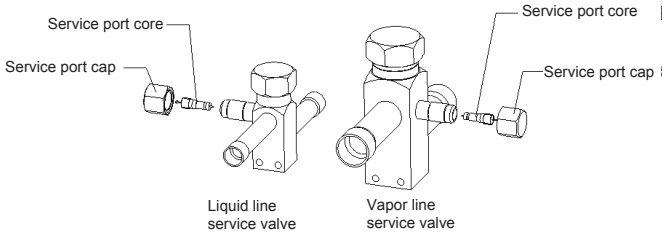

Fig.7

### 3.3 Attach Gauge

Flow regulated nitrogen (at 1 to 2 psig) through the low-side refrigeration gauge set into the liquid line service port valve, and out of the vapor line service port valve.

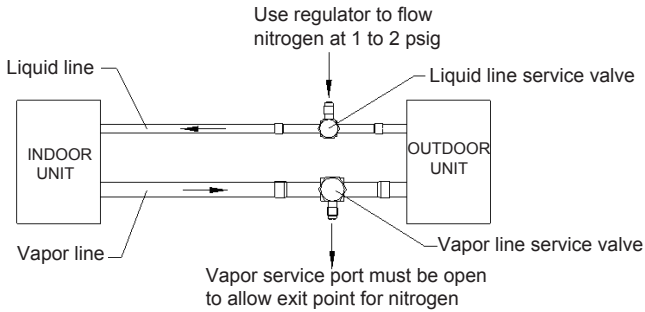

Fig.8

### 3.4 Braze Line Set

To help protect service valve seals during brazing, wrap water saturated cloths around service valve bodies and copper tube stubs. Water saturated cloths must remain water saturated throughout the brazing and cool-down process.

Braze line to the service valve.

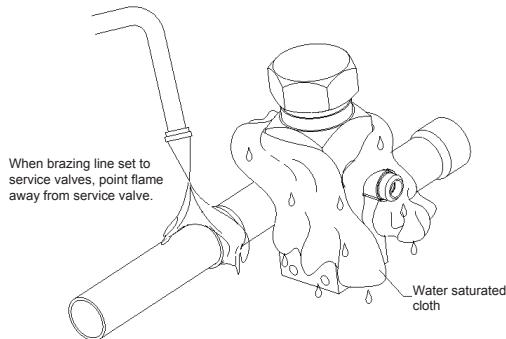

Fig.9

### 3.5 Preparation for Next Step

After all connections have been brazed, disconnect manifold gauge set from service ports. Apply water saturated cloths to both services valves to cool piping. Once piping is cool, remove all water saturated cloths. Reinstall service cap and core. Refer to the unit installation instructions for the next step in preparing the unit.

### 4. Check Piston

There is a piston located in outdoor condensing unit, please verify the piston size based on the below table. When matching with air handler, please make sure replace this piston in air handler.

Table 3

OUTDOOR UNIT	INDOOR UNIT	PISTON KIT PART NO.
33VB018C24	21DT018C24	053
33VB024C24	21DT024C24	054
33VB030C24	21DT030C24	064
33VB036C24	21DT036C24	067
33VB042C24	21DT042C24	071
33VB048C24	21DT048C24	079
33VB060C24	21DT060C24	084
33VB018H24	21DT018C24	055
33VB024H24	21DT024C24	057
33VB030H24	21DT030C24	068
33VB036H24	21DT036C24	067
33VB042H24	21DT042C24	073
33VB048H24	21DT048C24	082
33VB060H24	21DT060C24	091

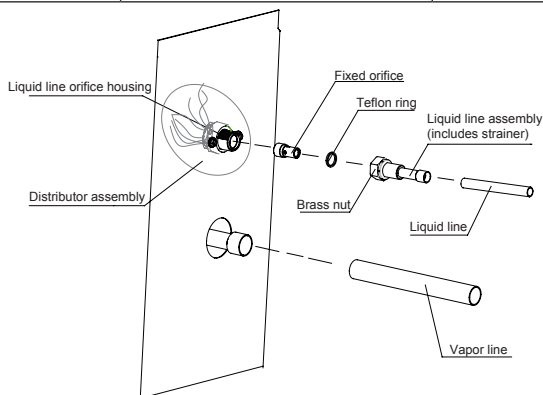

Fig.10

## 5. Operating Gauge Set and Service Valves

These instructions are intended as a general guide and do not supersede local codes in any way. Consult authorities who have jurisdiction before installation.

### 6.1 Torque Requirements

When servicing or repairing heating, ventilating, and air conditioning components, ensure the fasteners are appropriately tightened. Table 4 lists torque values for fasteners.



### **IMPORTANT**

Only use Allen wrenches of sufficient hardness (50Rc –Rockwell Harness Scale minimum). Fully insert the wrench into the valve stem recess.

Service valve stems are factory–torqued (from 9 ft–lbs for small valves, to 25 ft–lbs for large valves) to prevent refrigerant loss during shipping and handling. Using an Allen wrench rated at less than 50Rc risks rounding or breaking off the wrench, or stripping the valve stem recess.

To prevent stripping of the various caps used, the appropriately sized wrench should be used and fitted snugly over the cap before tightening.

Table 4. Torque Requirements

Parts	Recommended Torque	
Service valve cap	8 ft.– lb.	11 NM
Sheet metal screws	16 in.– .lb	2 NM
Machine screws #10	28 in.– lb.	3 NM
Compressor bolts	90 in.– lb.	10 NM
Gauge port seal cap	8 ft.– lb.	11 NM

### 5.2 Using Manifold Gauge Set

When checking the system charge, only use a manifold gauge set that features low loss anti-blow back fittings.

Manifold gauge set used with HFC–410A refrigerant systems must be capable of handling the higher system operating pressures. The gauges should be rated for use with pressures of 0 – 800 psig on the high side and a low side of 30" vacuum to 250 psig with dampened speed to 500 psig. Gauge hoses must be rated for use at up to 800 psig of pressure with a 4000 psig burst rating.

### 5.3 Operating Service Valves

The liquid and vapor line service valves are used for removing refrigerant, flushing, leak testing, evacuating, checking charge and charging.

Each valve is equipped with a service port which has a factory–installed valve stem. Figure 11 provides information on how to access and operating both angle service valves.

### 5.4 Operating Angle Type Service Valve

- 1). Remove stem cap with an appropriately sized wrench.
- 2). Use a service wrench with a hex–head extension (3/16" for liquid line valve sizes and 5/16" for vapor line valve sizes) to back the stem out counterclockwise as far as it will go.

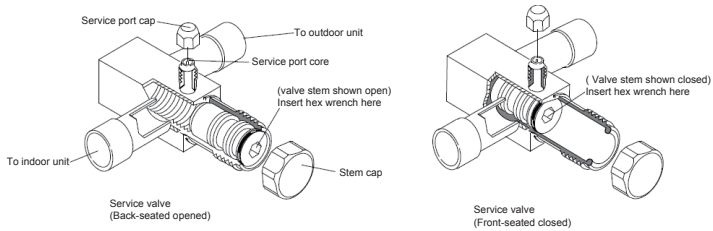
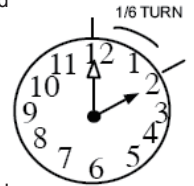

Fig.11

## 5.5 To Access Service Port

A service port cap protects the service port core from contamination and serves as the primary leak seal.

- 1). Remove service port cap with an appropriately sized wrench.
- 2). Connect gauge set to service port.
- 3). When testing is completed, replace service port cap and tighten as follows
  - With torque wrench: Finger tighten and torque cap per table 4.
  - Without torque wrench: Finger tighten and use an appropriately sized wrench to turn an additional 1/6 turn clockwise.



## 5.6 Reinstall Stem Cap

Stem cap protects the valve stem from damage and serves as the primary seal. Replace the stem cap and tighten as follows:

- With Torque Wrench: Finger tighten and then torque cap per table 4.
- Without Torque Wrench: Finger tighten and use an appropriately sized wrench to turn an additional 1/12 turn clockwise.

**NOTE:** A label with specific torque requirements may be affixed to the stem cap. If the label is present, use the specified torque.

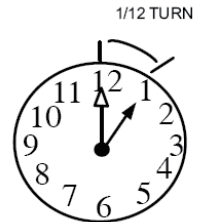

## 5.7 Install Liquid Line Filter Drier Indoor

Refer to Fig. 12 and install filter drier as follows:

- 1). Braze 5 in. liquid tube to the indoor coil.
- 2). Wrap filter drier with damp cloth.
- 3). Braze filter drier to 5 in. long liquid tube from step 1.
- 4). Connect and braze liquid refrigerant tube to the filter drier.

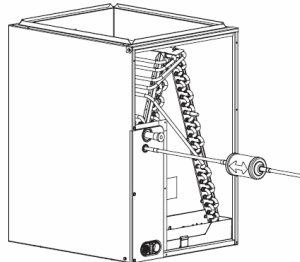

Fig.12—Liquid Line Filter Drier

## 6. Recovering Refrigerant from Existing System

### 6.1 Disconnect Power

Disconnect all power to the existing outdoor unit at the disconnect switch or main fuse box/breaker panel.

### 6.2 Connect Manifold Gauge Set

Connect a gauge set, clean recovery cylinder and a recovery machine to the service ports of the existing unit. Use the instructions provided with the recovery machine to make the connections.

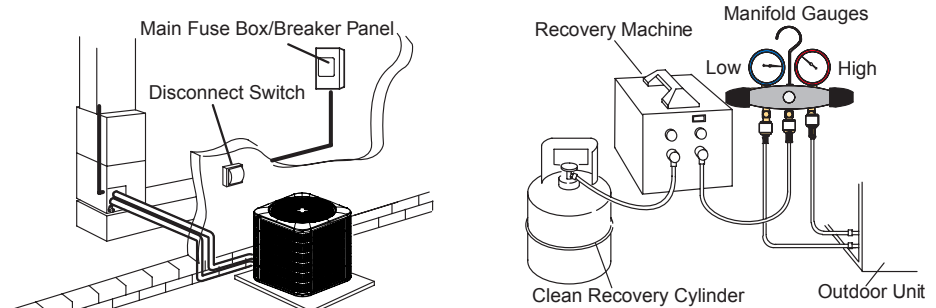

Fig.13

### 6.3 Recovering Refrigerant

Remove existing HCFC-410A refrigerant using one of the following procedures:

#### **METHOD 1:**

Use this method if the existing outdoor unit is not equipped with shut-off valves, or if the unit is not operational and you plan to use the existing HCFC-410A to flush the system.

Remove all HCFC-410A refrigerant from the existing system. Check gauges after shutdown to confirm that the entire system is completely void of refrigerant.

#### **METHOD 2:**

Use this method if the existing outdoor unit is equipped with manual shut-off valves, and you plan to use new HCFC-410A refrigerant to flush the system.

The following devices could prevent full system charge recovery into the outdoor unit:

- Outdoor unit's high or low-pressure switches (if applicable) when tripped can cycle the compressor OFF.
- Compressor can stop pumping due to tripped internal pressure relief valve.
- Compressor has internal vacuum protection that is designed to unload the scrolls (compressor stops pumping) when the pressure ratio meets a certain value or when the suction pressure is as high as 20 psig. (Compressor suction pressures should never be allowed to go into a vacuum. Prolonged operation at low suction pressures will result in overheating of the scrolls and permanent damage to the scroll tips, drive bearings and internal seals.)

Once the compressor can not pump down to a lower pressure due to one of the above system conditions, shut off the vapor valve. Turn OFF the main power to unit and use a recovery machine to recover any refrigerant left in the indoor coil and line set.

Perform the following task:

- a. Start the existing HCFC-410A system in the cooling mode and close the liquid line valve.
- b. Use the compressor to pump as much of the existing HCFC-410A refrigerant into the outdoor unit until the outdoor system is full. Turn the outdoor unit main power OFF and use a recovery machine to remove the remaining refrigerant from the system.

**NOTE:** It may be necessary to bypass the low pressure switches (if equipped) to ensure complete refrigerant evacuation.

- c. When the low side system pressures reach 0 psig, close the vapor line valve.
- d. Check gauges after shutdown to confirm that the valves are not allowing refrigerant to flow back into the low side of the system.

## 6.4 Leak Test Line Set and Indoor Coil

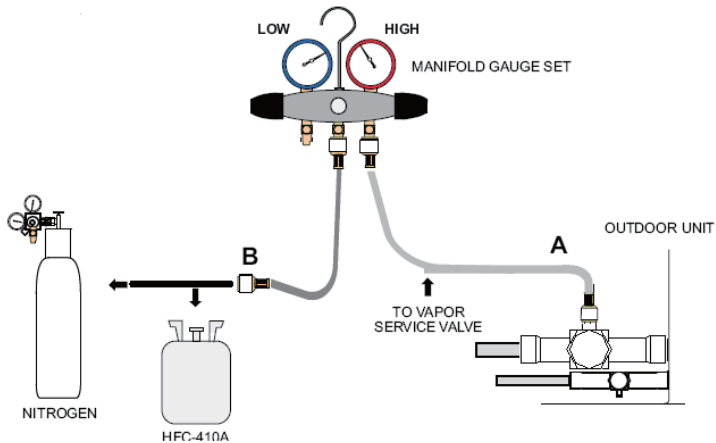

Fig.14—Leak Test

### 6.4.1 Connect Gauge Set

- 1). Connect an HFC-410A manifold gauge set high pressure hose to the vapor valve service port.

**NOTE:** Normally, the high pressure hose is connected to the liquid line port. However, connecting it to the vapor port better protects the manifold gauge set from high pressure damage.

- 2). With both manifold valves closed, connect the cylinder of HFC-410A refrigerant to the center port of the manifold gauge set.

**NOTE:** Later in the procedure, the HFC-410A container will be replaced by the nitrogen container.

### 6.4.2 Test For Leaks

After the line set has been connected to the indoor and outdoor units, check the line set connections and indoor unit for leaks. Use the following procedure to test for leaks:

- 1). With both manifold valves closed, connect the cylinder of HFC-410A refrigerant to the center

- port of the manifold gauge set. Open the valve on the HFC-410A cylinder (vapor only).
- Open the high pressure side of the manifold to allow HFC-410A into the line set and indoor unit. Weigh in a trace amount of HFC-410A. [A trace amount is a maximum of two ounces (57 g) refrigerant or three pounds (31 kPa) pressure]. Close the valve on the HFC-410A cylinder and the valve on the high pressure side of the manifold gauge set. Disconnect the HFC-410A cylinder.
  - Connect a cylinder of dry nitrogen with a pressure regulating valve to the center port of the manifold gauge set.
  - Adjust dry nitrogen pressure to 150 psig (1034 kPa). Open the valve on the high side of the manifold gauge set in order to pressurize the line set and the indoor unit.
  - After a few minutes, open one of the service valve ports and verify that the refrigerant added to the system earlier is measurable with a leak detector.
  - After leak testing disconnect gauges from service ports.

## 6.5 Evacuating Line Set and Indoor Coil

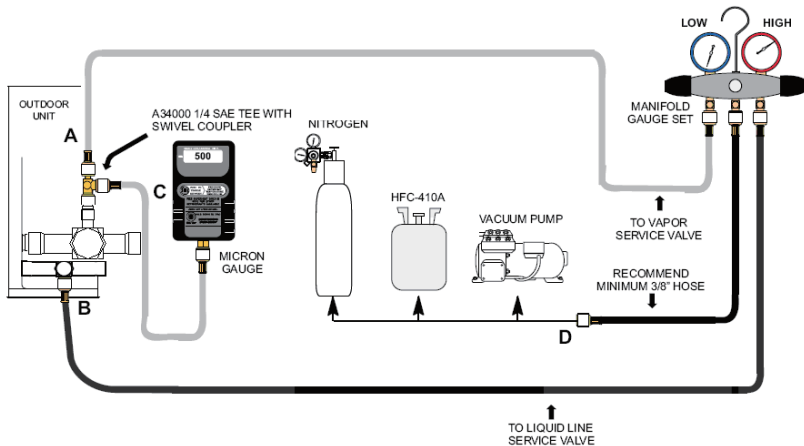

Fig.15—Evacuating System

### 6.5.1 Connect Gauge Set

**NOTE :** Remove cores from service valves (if not already done).

- Connect low side of manifold gauge set with 1/4 SAE in-line tee to vapor line service valve
- Connect high side of manifold gauge set to liquid line service valve
- Connect micron gauge available connector on the 1/4 SAE in-line tee.
- Connect the vacuum pump (with vacuum gauge) to the center port of the manifold gauge set.  
The center port line will be used later for both the HFC-410A and nitrogen containers.

### 7.5.2 Connect Gauge Set

- Open both manifold valves and start the vacuum pump.
- Evacuate the line set and indoor unit to an absolute pressure of 23,000 microns (29.01 inches of mercury).

**NOTE :** During the early stages of evacuation, it is desirable to close the manifold gauge valve at least once. A rapid rise in pressure indicates a relatively large leak. If this occurs, repeat the leak



testing procedure.

**NOTE:** The term absolute pressure means the total actual pressure within a given volume or system, above the absolute zero of pressure. Absolute pressure in a vacuum is equal to atmospheric pressure minus vacuum pressure.

- 3). When the absolute pressure reaches 23,000 microns (29.01 inches of mercury), perform the following:
    - Close manifold gauge valves
    - Close valve on vacuum pump
    - Turn off vacuum pump
    - Disconnect manifold gauge center port hose from vacuum pump
    - Attach manifold center port hose to a dry nitrogen cylinder with pressure regulator set to 150 psig (1034 kPa) and purge the hose.
      - Open manifold gauge valves to break the vacuum in the line set and indoor unit.
      - Close manifold gauge valves.
  - 4). Shut off the dry nitrogen cylinder and remove the manifold gauge hose from the cylinder. Open the manifold gauge valves to release the dry nitrogen from the line set and indoor unit.
  - 5). Reconnect the manifold gauge to the vacuum pump, turn the pump on, and continue to evacuate the line set and indoor unit until the absolute pressure does not rise above 500 microns (29.9 inches of mercury) within a 20-minute period after shutting off the vacuum pump and closing the manifold gauge valves.
  - 6). When the absolute pressure requirement above has been met, disconnect the manifold hose from the vacuum pump and connect it to an upright cylinder of HFC-410A refrigerant. Open the manifold gauge valve 1 to 2 psig in order to release the vacuum in the line set and indoor unit.
  - 7). Perform the following:
    - Close manifold gauge valves.
    - Shut off HFC-410A cylinder.
    - Reinstall service valve cores by removing manifold hose from service valve.
- Quickly install cores with core tool while maintaining a positive system pressure.
- Replace stem caps and secure finger tight, then tighten an additional one-sixth (1/6) of a turn as illustrated.

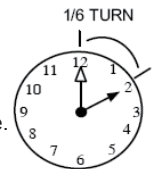

## 7. Electrical

In the U.S.A., wiring must conform with current local codes and the current National Electric Code (NEC). In Canada, wiring must conform with current local codes and the current Canadian Electrical Code (CEC).

Refer to the furnace or air handler installation instructions for additional wiring application diagrams and refer to unit nameplate for minimum circuit ampacity and maximum overcurrent protection size.

### 24VAC TRANSFORMER

Use the transformer provided with the furnace or air handler for low-voltage control power (24VAC – 40 VA minimum).

### 7.1 Size Circuit And Install Disconnect Switch

Refer to the unit nameplate for minimum circuit ampacity, and maximum fuse or circuit breaker (HACR per NEC). Install power wiring and properly sized disconnect switch.

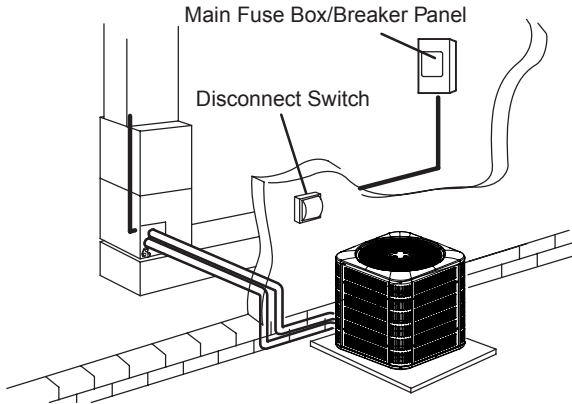

Fig.16

**NOTE:** Units are approved for use only with copper conductors. Ground unit at disconnect switch or to an earth ground.

### 7.2 Install Thermostat

Install room thermostat (ordered separately) on an inside wall approximately in the center of the conditioned area and 5 feet (1.5m) from the floor. It should not be installed on an outside wall or where it can be affected by sunlight or drafts.

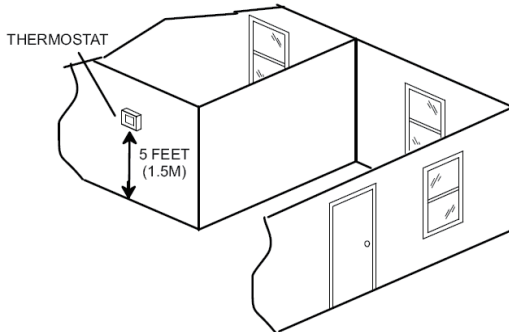

Fig.17

**NOTE:** 24VAC, Class II circuit connections are made in the control panel.

### 7.3 Unit Low Voltage Connections

- High voltage field wiring
- Low voltage (24v) field wiring

Table 5

WIRE RUN LENGTH	AWG#	INSULATION TYPE
LESS THAN 100' (30 METERS)	18	Temperature Rating
MORE THAN 100' (30 METERS)	16	35°C Minimum

**A** Run 24VAC control wires through cutout with grommet.

**B** Run 24VAC control wires through wire tie.

**C** Make 24VAC control wire connections.

**NOTE:** Wire tie provides low voltage wire strain relief and to maintain separation of field low and high voltage circuits

**NOTE:** For proper voltages, select thermostat wire (control wires) gauge per table above.

**NOTE:** Do not bundle any excess 24VAC control wires inside control box.

#### 7.4 Unit High Voltage Connections

**A** Run HIGH VOLTAGE control wires through cutout with grommet.

**B** Make HIGH VOLTAGE control wires connections.

**C** Tighten wire tie to security HIGH VOLTAGE control wiring.

**NOTE:** Any excess high voltage field wiring should be trimmed and secured away from any low voltage field wiring

**NOTE:** To facilitate a conduit, a cutout is located in the bottom of the control box. Connect conduit to the control box using a proper conduit fitting.

**NOTE:** The signal line of the wired controller must be separated from the power line and the connecting line between the indoor unit and the outdoor unit.

#### Important Electric Data

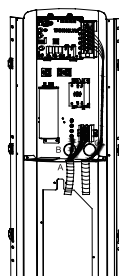
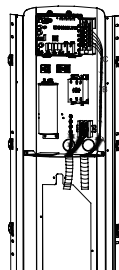

Table 6

Model	Compressor				Fan Motor	Fuse/Breaker Capacity	Min. Power Supply Cord
	Power Supply	Qty.	RLA	LRA	FLA		
	V/Ph/Hz	-	A	A	A		
33VB018C24	208/230/1/60	1	7.9	38	1.2	15	AWG16
33VB024C24	208/230/1/60	1	9.8	53	1.2	20	AWG14
33VB030C24	208/230/1/60	1	12.6	71	1.2	25	AWG12
33VB036C24	208/230/1/60	1	15.08	64	1.7	35	AWG12
33VB042C24	208/230/1/60	1	21.5	105	1.7	50	AWG10
33VB048C24	208/230/1/60	1	21	115	1.7	45	AWG10
33VB060C24	208/230/1/60	1	25	150	2.1	50	AWG8
33VB018H24	208/230/1/60	1	7.5	38	0.8	15	AWG16
33VB024H24	208/230/1/60	1	9.8	53	1.2	20	AWG14
33VB030H24	208/230/1/60	1	12.5	71	0.7	25	AWG12

33VB036H24	208/230/1/60	1	15.08	64	1.7	35	AWG12
33VB042H24	208/230/1/60	1	17	112	1.7	35	AWG10
33VB048H24	208/230/1/60	1	21	115	1.7	45	AWG10
33VB060H24	208/230/1/60	1	24.5	134	2.3	50	AWG8

Electric Wiring Design

Model:33VB018C24; 33VB024C24; 33VB030C24; 33VB036C24; 33VB042C24  
 33VB048C24; 33VB060C24

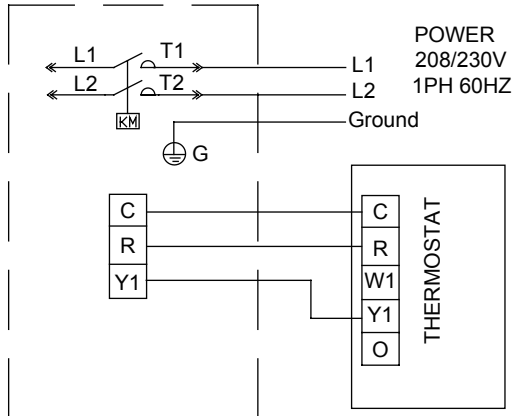

Fig.18

Model: 33VB018H24; 33VB024H24; 33VB030H24; 33VB036H24

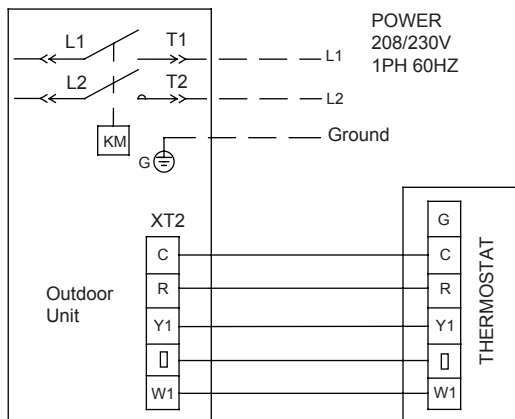

Fig.19

Model: 33VB042H24; 33VB048H24; 33VB060H24.

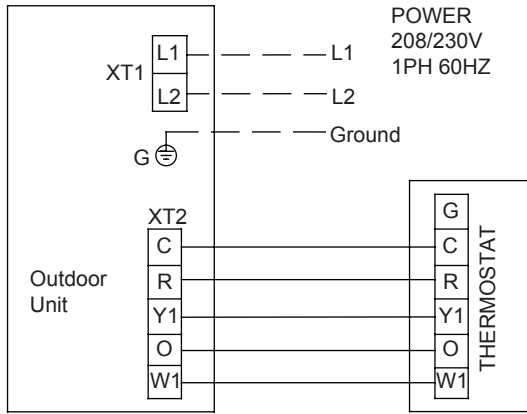

Fig.20

**18-36k Circuit Diagram**

Model:33VB018C24; 33VB024C24; 33VB030C24; 33VB036C24.

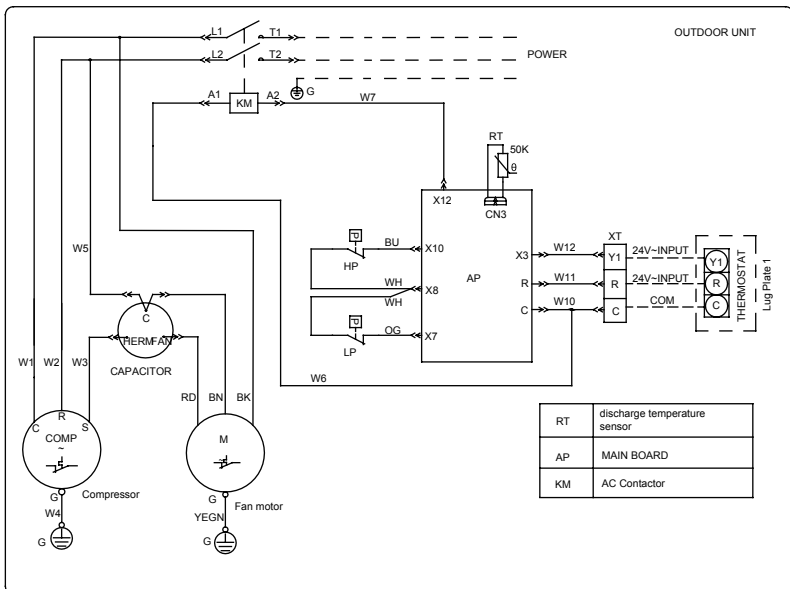

Fig.21

### 42-60k Circuit Diagram

Model: 33VB042C24; 33VB048C24; 33VB060C24.

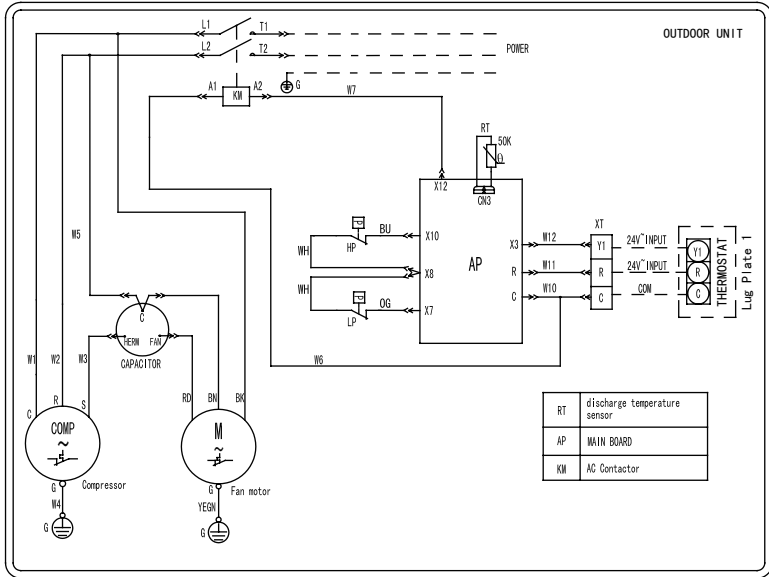

Fig.22

### 18-36k Circuit Diagram

Model: 33VB018H24; 33VB024H24; 33VB030H24; 33VB036H24.

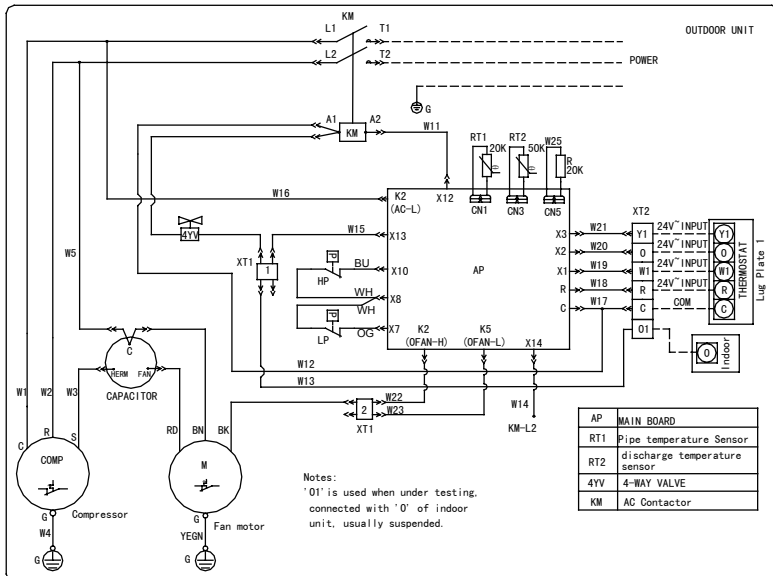

Fig.23

## 42-60k Circuit Diagram

Model:33VB042H24; 33VB048H24; 33VB060H24.

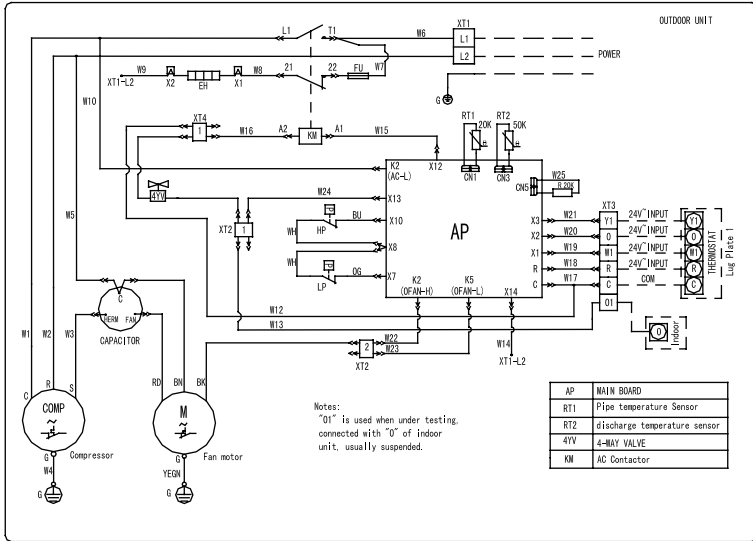

Fig.24

## 8. System Refrigerant

This section outlines procedures for:

- Connecting gauge set for testing and charging.
- Adding or removing refrigerant.

### 9.1 Gauge Set (Cooling Only)

Connections for testing and charging.

- Close manifold gauge set valves and connect the center hose to a cylinder of HFC-410A.
- Set for liquid phase charging.
- Connect the manifold gauge set's low pressure side to the suction line service port.
- Connect the manifold gauge set's high pressure side to the liquid line service port.
- Position temperature sensor on vapor line near liquid line service port.

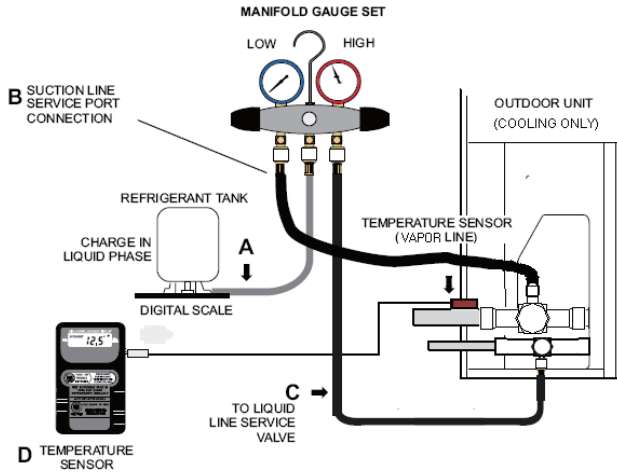

Figure 25. Gauge Set Setup and Connections for cooling only

## 8.2 Gauge Set (Heat Pump)

Connections for testing and charging.

- A** Close manifold gauge set valves and connect the center hose to a cylinder of HFC-410A.
- B** Connect the manifold gauge set's low pressure side to the true suction port.
- C** Connect the manifold gauge set's high pressure side to the liquid line service port.
- D** Position temperature sensor on the suction line near the compressor.

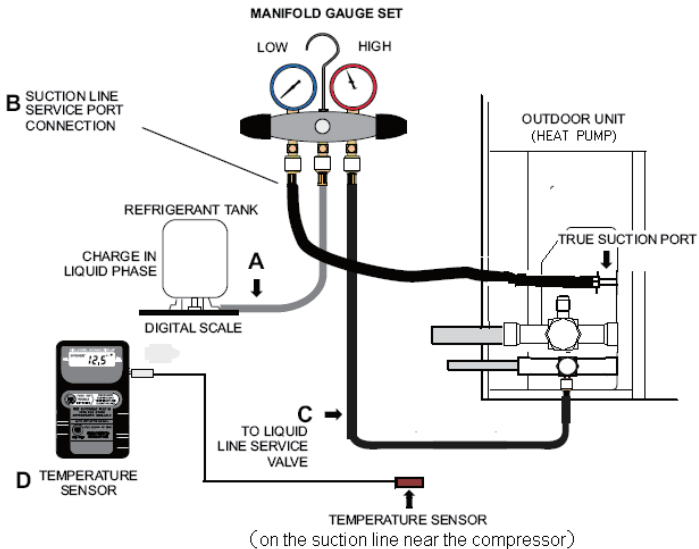

Figure 26. Gauge Set Setup and Connections for heat pump



### 8.3 Weigh In

Calculating system charge for outdoor unit lack of refrigerant

If the system is lack of refrigerant, first, locate and repair any leaks and then weigh in the refrigerant charge into the unit. To calculate the total refrigerant charge:

$$\begin{array}{l} \text{Amount specified} \\ \text{on nameplate} \end{array} + \begin{array}{l} \text{Adjust amount for variation} \\ \text{in line set length listed on} \\ \text{line set length table below} \end{array} = \text{Total charge}$$

Refrigerant Charge per Line Set Length:

Table 7

Outdoor Unit	Liquid Line Set Diameter	Ounces per 5 feet (g per 1.5 m) adjust from 25 feet (7.6 m) line set*
COOLING ONLY	3/8" (9.5 mm)	1.6 ounce per 5 feet (45g per 1.5 m)
	1/2"(12.7 mm)	3.2 ounce per 5 feet (90g per 1.5 m)
HEAT PUMP	3/8" (9.5 mm)	2.9 ounce per 5 feet (81g per 1.5 m)
	1/2"(12.7 mm)	5.9 ounce per 5 feet (165g per 1.5 m)

\*If line length is greater than 25 ft. (7.6 m), add this amount. If line length is less than 25 ft. (7.6 m), subtract this amount.

**NOTE:** Insulate liquid line when it is routed through areas where the surrounding ambient temperature could become higher than the temperature of the liquid line or when pressure drop is equal to or greater than 20 psig.

**NOTE:** The above nameplate is for illustration purposes only. Go to actual nameplate on outdoor unit for charge information.

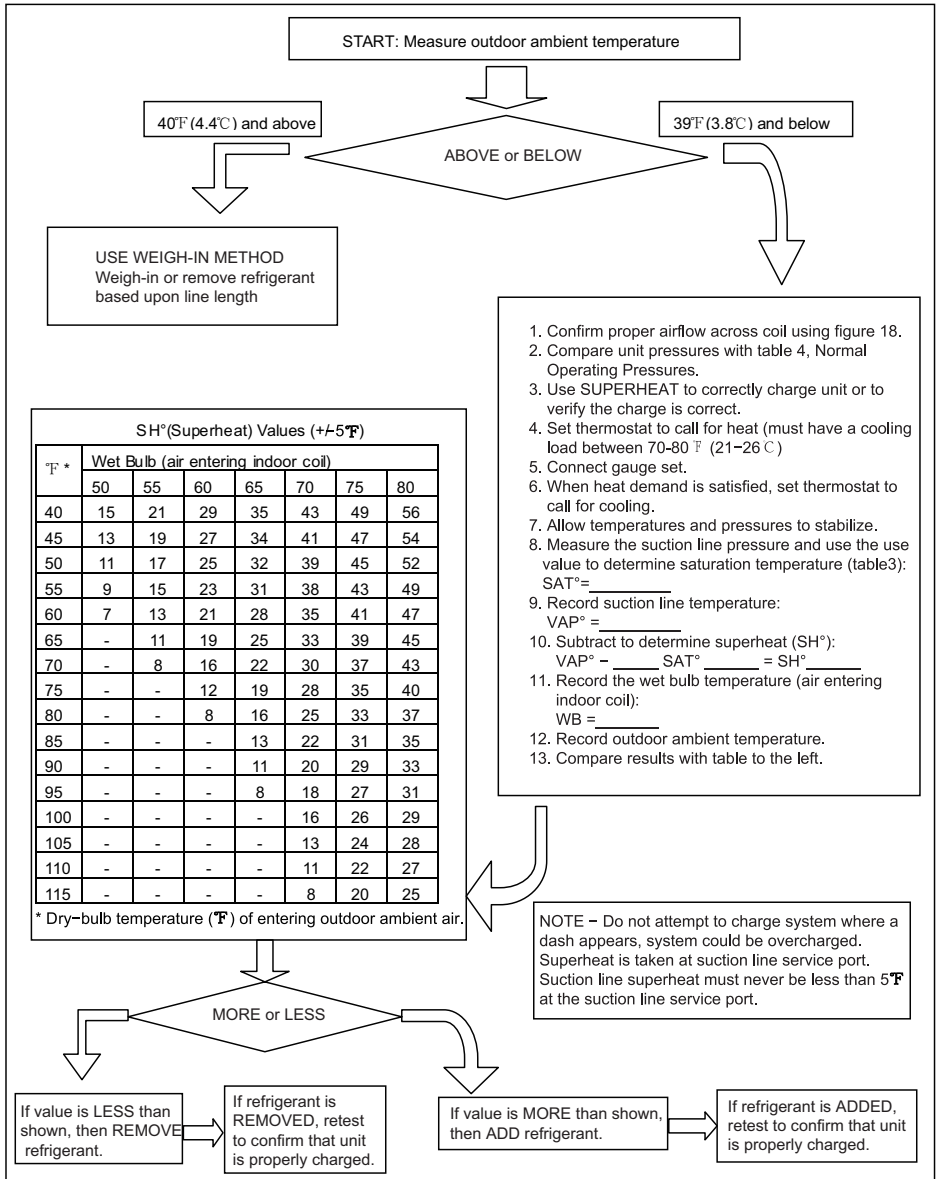

MORE or LESS

If value is LESS than shown, then REMOVE refrigerant.

If value is MORE than shown, then ADD refrigerant.

If refrigerant is REMOVED, retest to confirm that unit is properly charged.

If refrigerant is ADDED, retest to confirm that unit is properly charged.

NOTE - Do not attempt to charge system where a dash appears, system could be overcharged. Superheat is taken at suction line service port. Suction line superheat must never be less than 5°F at the suction line service port.

Figure 27. HFC-410A Superheat RFC Method

Table 8. Normal Operating Pressures – Liquid +10 and Vapor +5 PSIG\* (All Models)

°F (°C) **	33VB018H24	33VB024H24	33VB030H24	33VB036H24
	Liquid / Vapor	Liquid / Vapor	Liquid / Vapor	Liquid / Vapor
Heating				
60(15)	346/139	352 / 138	338 / 137	350 / 134
50(10)	323/117	331/114	334/112	331/117
40(4)	306/98	304/99	312/93	313/97
30(-1)	278/84	299/80	302/74	298/83
20(-7)	273/66	283/66	280/53	284/66
Cooling				
65(18)	226/140	233/137	238/138	220/138
70(21)	244/141	252/138	263/139	236/140
75(24)	263/142	271/140	279/139	256/141
80(27)	283/143	292/141	299/140	276/142
85(29)	302/144	314/142	324/141	298/143
90(32)	328/145	338/143	340/142	321/144
95(35)	351 / 146	361 / 145	375 / 145	344 / 144
100(38)	376 / 147	387 / 146	397 / 145	369 / 146
105(41)	402 / 148	412 / 147	424 / 147	394 / 147
110(43)	430 / 149	441 / 148	454 / 150	421 / 148
115(46)	465 / 150	471 / 151	485 / 150	449 / 149
*IMPORTANT—These are most popular match-up pressures. Indoor match up, indoor air quality, and indoor load cause pressures to vary.				
**Temperature of the air entering the outside coil.				

°F (°C) **	33VB042H24	33VB048H24	33VB060H24
	Liquid / Vapor	Liquid / Vapor	Liquid / Vapor
Heating			
60(15)	373 / 139	355/130	351/117
50(10)	363/117	336/113	333/105
40(4)	348/97	315/88	316/88
30(-1)	336/74	296/72	308/70
20(-7)	322/64	286/64	300/61
Cooling			
65(18)	223/125	231/136	243/136
70(21)	241/130	248/139	263/137
75(24)	261/134	271/140	282/138

80(27)	282/138	291/142	306/139
85(29)	302/139	312/143	327/140
90(32)	326/140	335/144	351/141
95(35)	349 / 141	359 / 145	376 / 142
100(38)	374 / 142	384 / 146	401 / 143
105(41)	399 / 143	411 / 148	426 / 145
110(43)	428 / 145	439 / 149	452 / 146
115(46)	455 / 146	468 / 150	484 / 148

\*IMPORTANT—These are most popular match-up pressures. Indoor match up, indoor air quality, and indoor load cause pressures to vary.

\*\*Temperature of the air entering the outside coil.

Table 9. HFC-410A Temperature (°F) - Pressure (Psig)

T	Psig	T	Psig	T	Psig	T	Psig	T	Psig	T	Psig	T	Psig	T	Psig
32	100.8	48	137.1	63	178.5	79	231.6	94	290.8	110	365.0	125	445.9	141	545.6
33	102.9	49	139.6	64	181.6	80	235.3	95	295.1	111	370.0	126	451.8	142	552.3
34	105.0	50	142.2	65	184.3	81	239.0	96	299.4	112	375.1	127	457.6	143	559.1
35	107.1	51	144.8	66	187.7	82	242.7	97	303.8	113	380.2	128	463.5	144	565.9
36	109.2	52	147.4	67	190.9	83	246.5	98	308.2	114	385.4	129	469.5	145	572.8
37	111.4	53	150.1	68	194.1	84	250.3	99	312.7	115	390.7	130	475.6	146	579.8
38	113.6	54	152.8	69	197.3	85	254.1	100	317.2	116	396.0	131	481.6	147	586.8
39	115.8	55	155.5	70	200.6	86	258.0	101	321.8	117	401.3	132	487.8	148	593.8
40	118.0	56	158.2	71	203.9	87	262.0	102	326.4	118	406.7	133	494.0	149	601.0
41	120.3	57	161.0	72	207.2	88	266.0	103	331.0	119	412.2	134	500.2	150	608.1
42	122.6	58	163.9	73	210.6	89	270.0	104	335.7	120	417.7	135	506.5	151	615.4
43	125.0	59	166.7	74	214.0	90	274.1	105	340.5	121	423.2	136	512.9	152	622.7
44	127.3	60	169.6	75	217.4	91	278.2	106	345.3	122	428.8	137	519.3	153	630.0
45	129.7	61	172.6	76	220.9	92	282.3	107	350.1	123	434.5	138	525.8	154	637.5
46	132.2	62	175.4	77	224.4	93	286.5	108	355.0	124	440.2	139	532.4	155	645.0
47	134.6			78	228.0			109	360.0			140	539.0		

# 9. Unit Control

## 10.1 Mainboard Description

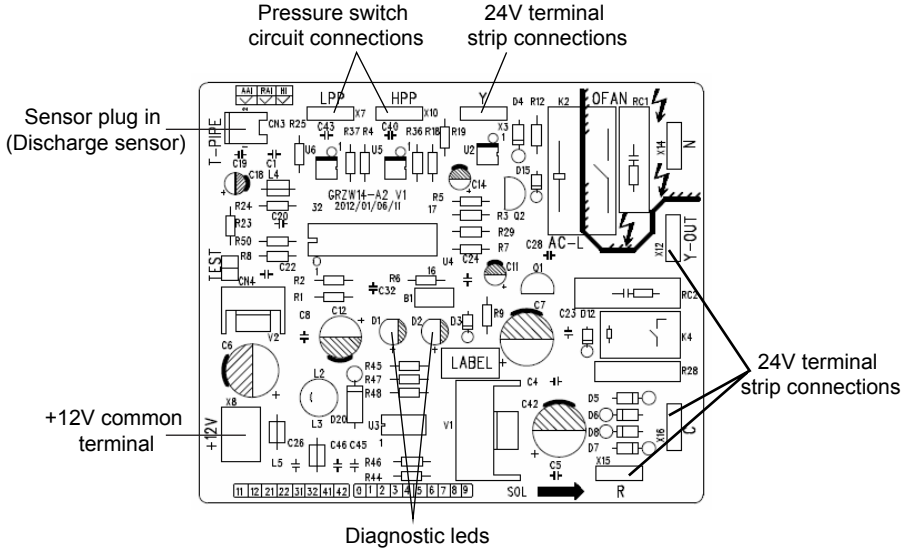

Fig.28 Mainboard Description for cooling only

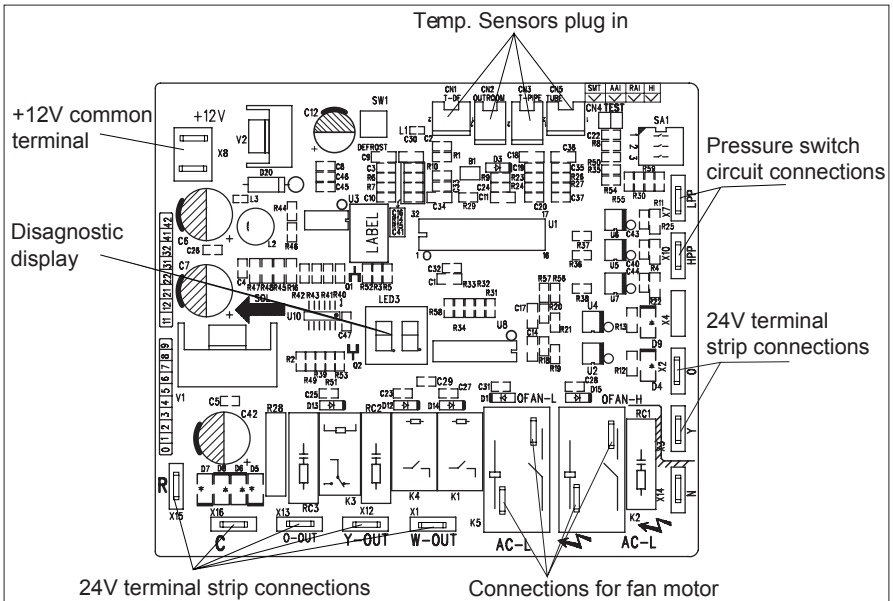

Fig.29 Mainboard Description for Heat pump unit

## 9.2 Terminal Description

Table 10. Demand Control Board Description for cooling only unit

ID	Description
X12(Y-OUT)	24 VAC output connection for compressor operation
X7(LPP)	Connection for low-pressure switch
X10(HPP)	Connection for high-pressure switch
X3(Y)	24 VAC input for compressor operation
CN3(T-PIPE)	Connection for discharge temperature sensor.
X16(C)	24 VAC system common
X15(R)	24 VAC system power input
X8(+12V)	Connection for low-pressure switch Connection for high-pressure switch

Table 11. Demand Control Board Description for Heat pump unit

ID	Description
X1(W-OUT)	Auxiliary electrical heater output
X2(O)	Connection for detecting the 24VAC control signal of 4-way valve
X3(Y)	Connection for detecting the 24VAC signal for compressor
X7(LPP)	Connection for low pressure switch
X8(+12V)	Connection for low pressure switch, Connection for high pressure switch
X10(HPP)	Connection for high pressure switch
X12(Y-OUT)	24 VAC output interface for compressor operation
X13(O-OUT)	24 VAC output interface for 4-way valve operation
X14(N)	220 VAC N input of fan motor
X15(R)	24 VAC system power input
X16(C)	24 VAC system common
CN1(T-DF)	Connection for temp.sensor of condenser
CN2(OUTROOM)	Connection for ambient temp.sensor
CN3(T-PIPE)	Connection for discharge temp.sensor
CN5(TUBE)	Connect 20k fixed resistance into reserved interface
K2-2(OFAN-H)	220VAC output for high speed of fan motor
K2-4(AC-L)	220VAC L input for high speed of fan motor
K5-2(OFAN-L)	220VAC output for low speed of fan motor
K5-4(AC-L)	220VAC L input for low speed of fan motor

### 9.3 Control Flowchart

#### Cooling Operation

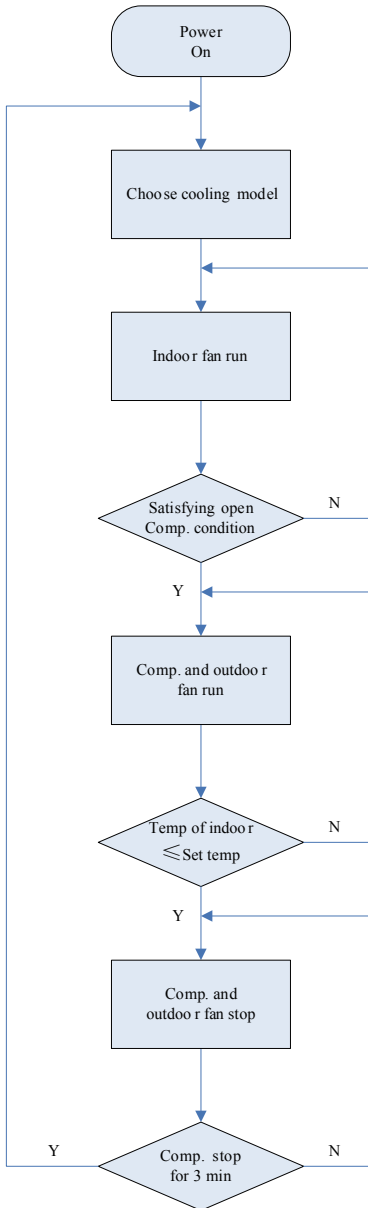

#### Heating Operation

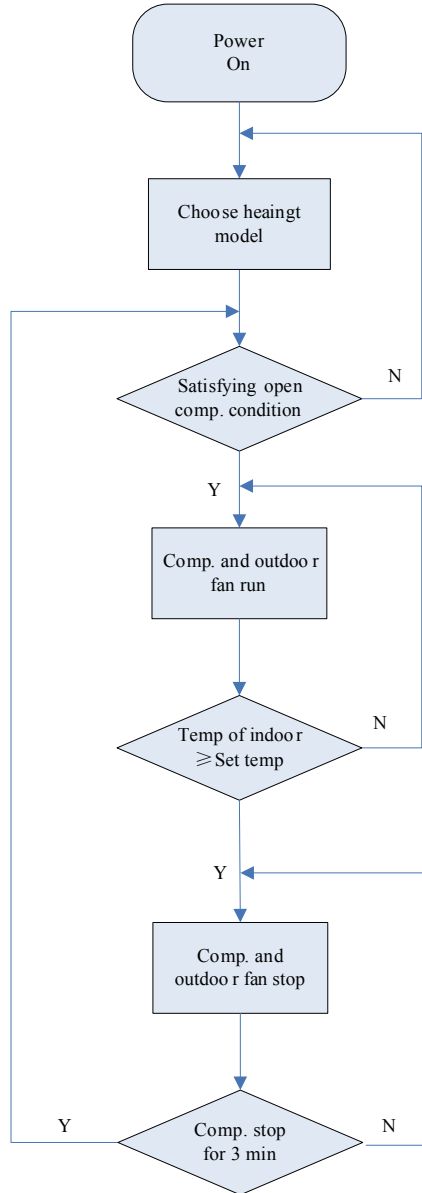

## 9.4 Error Analysis

### COOLING ONLY

#### DEMAND CONTROL BOARD DIAGNOSTICS

The state (Off, On, Flashing) of two LEDs on the control board (DS1 [Red] and DS2 [Red]) indicate diagnostics conditions that are described in table 12. See table 12 to determine control board operational conditions and to diagnose cause and solution to problems.

Table 12. Demand Control board Diagnostic LEDs

DS1 Red	DS2 Red	Trouble Case	Origin of Trouble	Measure
OFF	OFF	Power problem	No power (24V) to demand control board terminals R and C or demand control board failure.	<ol style="list-style-type: none"> <li>1 Check control transformer power (24V).</li> <li>2 If power is available to demand control board and LED(s) do not light, replace control board.</li> </ol>
<b>FAULT and LOCKOUT CODES (Each fault adds 1 strike to that code's counter; 3 strikes per 30 minutes = LOCKOUT)</b>				
0.5s Circulating Flash	OFF	Actuation of high pressure switch	High pressure switch	Abnormality is detected when the contact of the high pressure switch opens for 3 sec. The system will be shut down. The unit will report this fault. For the first two faults within 30 minutes, the unit can be recovered automatically. If over three times, the unit cannot be recovered automatically.
OFF	0.5s Circulating flash	Actuation of low pressure switch	Low pressure switch	When the unit runs more than 4 minutes or does not run, the low pressure switch opens for more than 3sec and the system will be shut down. The unit will report this fault. For the first two faults within 30 minutes, the unit can be recovered automatically. If over three times, the unit cannot be recovered automatically.



0.5s Circulating Flash	Continuous Light	Air discharge high-temperature protection of compressor	Exhaust over-temperature Protection	The exhaust temperature is higher than 125°C for more than 5s, the system will be shut down. After stopping the compressor for 3 mins, if the exhaust temperature is lower than 90°C for more than 5s, the compressor will re-start. For the first two faults within 30 minutes, the unit can be recovered automatically. If over three times, the unit cannot be recovered automatically.
Continuous Light	OFF	Malfunction of exhaust Temp. Sensor	Exhaust temperature sensor	If the exhaust temperature sensor is detected of open circuit 5 seconds successively after the compressor is started for 3 minutes or short circuit 5 seconds successively at any time The system will be shut down. After the fault is eliminated, the system can automatically resume to operation
0.5s Circulating Flash	0.5s Circulating flash	Normal operation	Unit operating normally or in standby mode.	None required.

## HEAT PUMP

Fault Display on the Dual 8 Numeral Tube of Outdoor Mainboard

Malfunction code	Trouble case	Origin of trouble signal	Measure
E1	Actuation of high pressure switch	High pressure switch	Abnormality is detected when the contact of the high pressure switch opens for 3 sec. The system will be shut down. The unit will report this fault. For the first two faults within 30 minutes, the unit can be recovered automatically. If over three times, the unit cannot be recovered automatically.
E3	Actuation of low pressure switch	Low pressure switch	When the unit runs more than 4 minutes or does not run, the low pressure switch opens for more than 3sec and the system will be shut down. The unit will report this fault. For the first two faults within 30 minutes, the unit can be recovered automatically. If over three times, the unit cannot be recovered automatically.

E4	Air discharge high-temperature protection of compressor	Exhaust over-temperature protection	The exhaust temperature is higher than 125°C for more than 5sec, the system will be shut down. After stopping the compressor for 3 mins, if the exhaust temperature is lower than 90°C for more than 5 sec, the compressor will re-start. For the first two faults within 30 minutes, the unit can be recovered automatically. If over three times, the unit cannot be recovered automatically.
F2	Malfunction of condenser temperature thermistor	Condenser temperature thermistor	Malfunction of condenser temperature thermistor is detected when there is a short circuit or an open circuit in the condenser temperature thermistor for more than 5 sec. The system will be shut down. The reset for the malfunction of condenser temperature thermistor is automatic.
F3	Malfunction of outdoor ambient temperature thermistor	Outdoor ambient temperature thermistor	Malfunction outdoor ambient temperature thermistor is detected when there is a short circuit or an open circuit in the outdoor ambient temperature thermistor for more than 5 sec. The system will be shut down. The reset for the malfunction of condenser temperature thermistor is automatic.
F4	Malfunction of Exhaust Temp. Sensor	Exhaust temperature sensor	If the exhaust temperature sensor is detected of open circuit 5 seconds successively after the compressor is started for 2 minutes or short circuit 5 seconds successively at any time .The system will be shut down. After the fault is eliminated, the system can automatically resume to operation.
oN	Normal operation	Unit operating normally or in standby mode.	None required.
H1	Defrost operation	Unit operating in defrost	None required.

## 9.5 Setting on Defrost Control PCB (for Heat Pump unit only)

There are 5 different defrost control settings you can choose by changing the dip switch located on Defrost Control PCB.

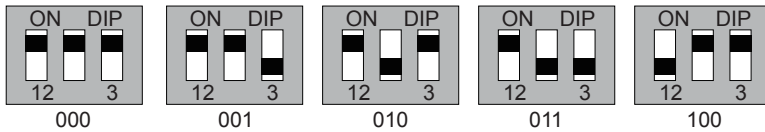

Fig.30

Table 13

	Without Outdoor Ambient Sensor installed				
Dip Switch Setting	000	001	010	011	100
t(min)	44	44	60	90	30
T1	28 °F	23 °F	32 °F	32 °F	32 °F
T2	59 °F	59 °F	68 °F	68 °F	68 °F

t-----Accumulation of compressor running time

T1-----Initiation Coil Temperature

T2-----Termination Coil Temperature

The factory default setting is "000". After the compressor consecutively runs for 44 minutes, the defrost cycle will be initiated if the sensor detects the coil temperature  $\leq 28$  F for consecutive 1 minute. The defrost cycle will be terminated either the coil temperature reach 59 F or the defrost cycle reach 15 minutes.

**Defrost Cycle:** when the system running in heat pump mode, after the compressor has been running for "t" minutes continuously, the defrost cycle start if the defrosting temp sensor has been in T1 degree or under T1 degree for 1 minute continuously. During the defrost cycle, the reversing valve is energized, the outdoor fan stops running and the auxiliary electric heating is energized. The defrost cycle will be terminated if defrost cycle reach 15 minutes or the coil sensor detects the coil temperature over T2 degree.

## 9.6 Manually Defrost Cycle

There is a Manually Defrost Button located on the Defrost Control PCB, by press this button, the system will go to defrost cycle right away to melt the ice on the coil.

Thank you for Choosing



---

[www.delta-dct.com](http://www.delta-dct.com)



66129916222